

Material: PP
180CC

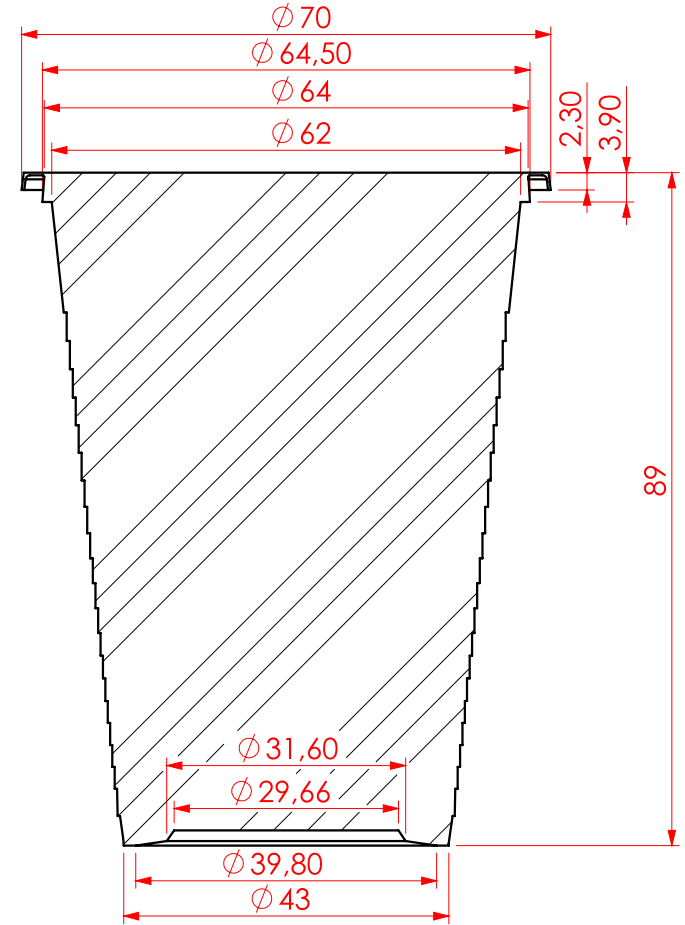

SECTION B - B

Approved by:	S. Nounev	General Tolerances:	
Control:	-	up to 6 mm	± 0.1
Date:	15.10.2018	6-30 mm	± 0.2
Piece:	-	30-120 mm	± 0.3
Material:	-	120-400 mm	± 0.5
Treatment:	-	400-1000 mm	± 0.8
Surface:	-	1000-2000 mm	± 1.2



MICROPACK LTD.
11 Gen. Kutuzov Str.
1618 Sofia, Bulgaria
VAT Reg. No.: BG109501889

tel.: +359 2 857 6910
mobile: +359 888 512 126
office@micropackplastics.com
www.micropackplastics.com

CUSTOMER DRAWING

	SCALE 1:1	A4	PRODUCT NAME: 180 CC CUP	REVISION:
	WEIGHT:	PAGE 1 OF 2	THIS DRAWING IS PROPERTY OF MICROPACK LTD.	

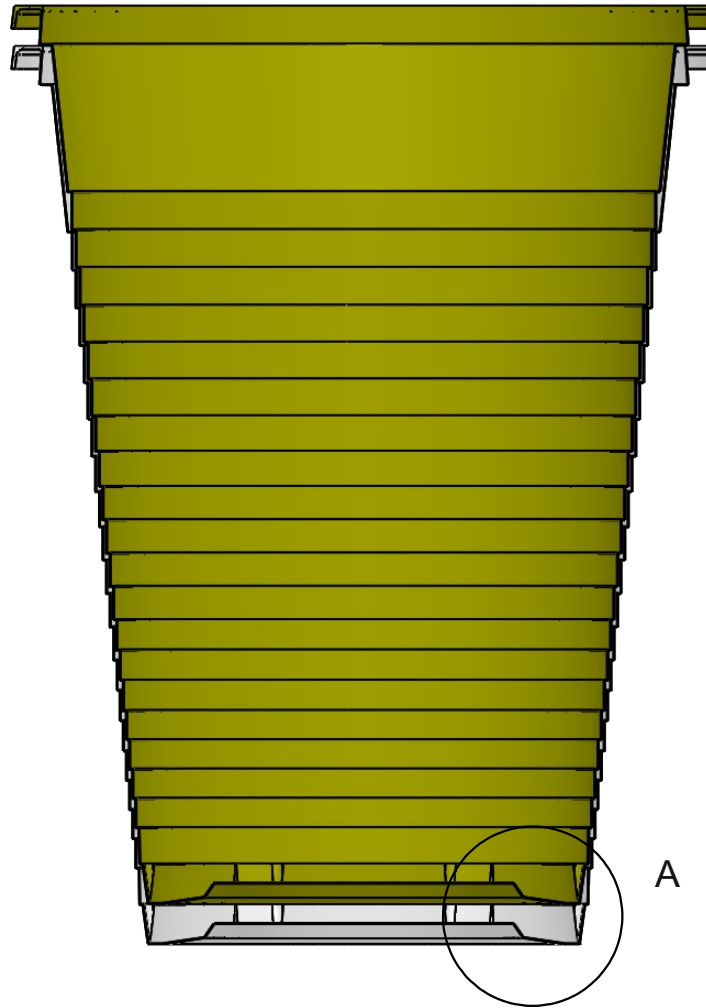
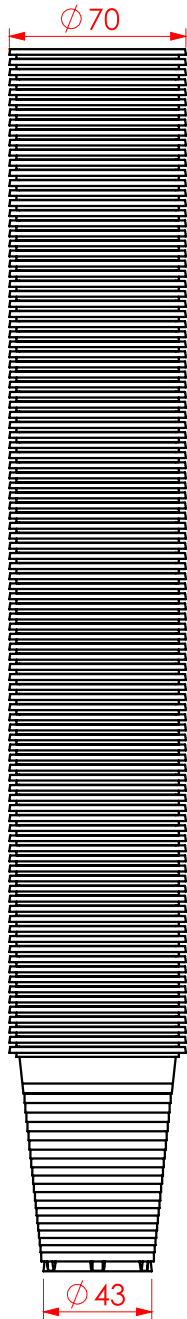

Material: PP
180CC

VIEW A

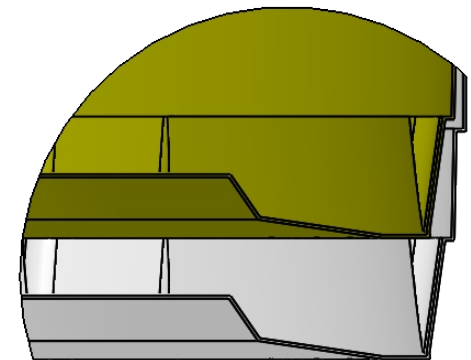

Approved by:	S. Nounev	General Tolerances:	
Control:	-	up to 6 mm	± 0.1
Date:	15.10.2018	6-30 mm	± 0.2
Piece:	-	30-120 mm	± 0.3
Material:	-	120-400 mm	± 0.5
Treatment:	-	400-1000 mm	± 0.8
Surface:	-	1000-2000 mm	± 1.2